

A VIEW

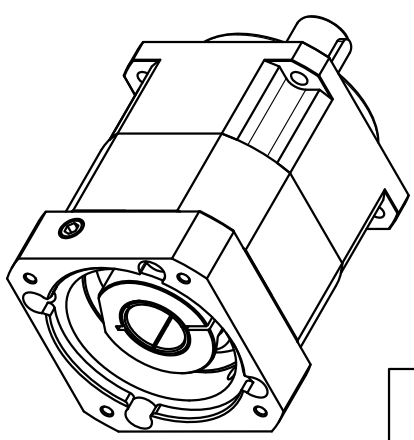
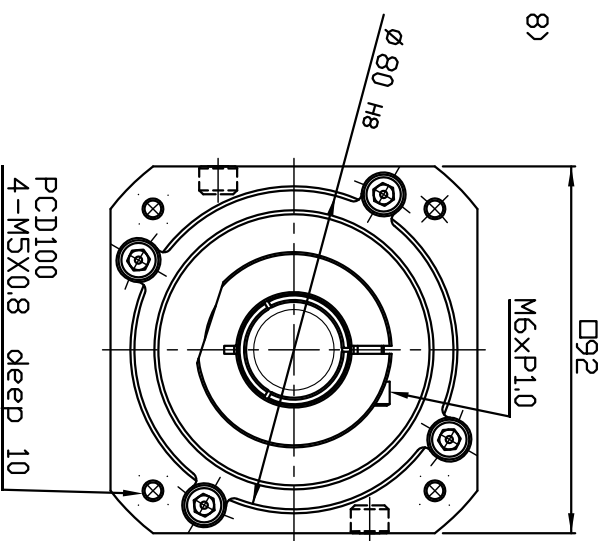
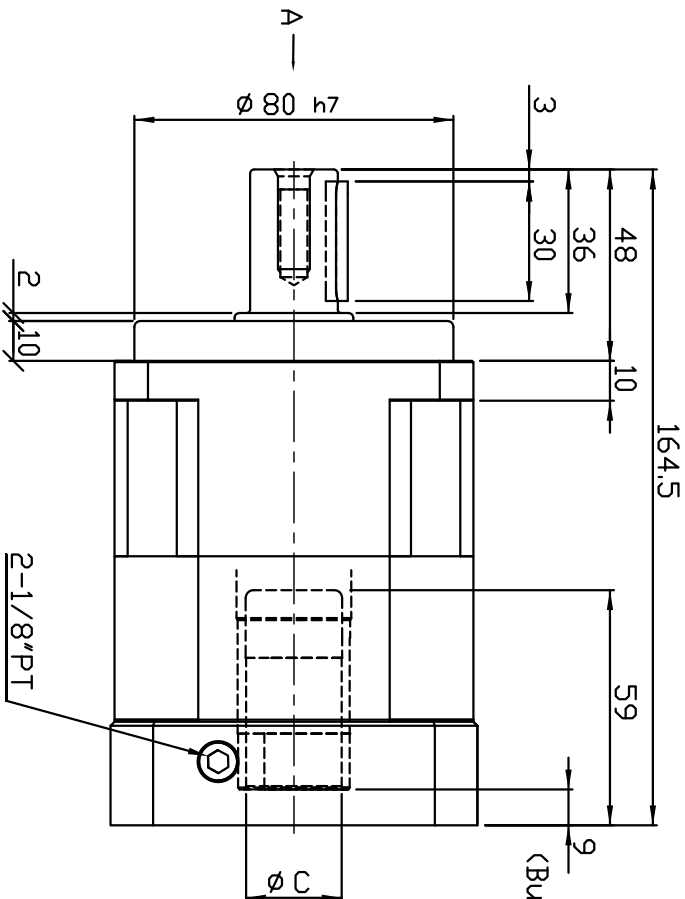
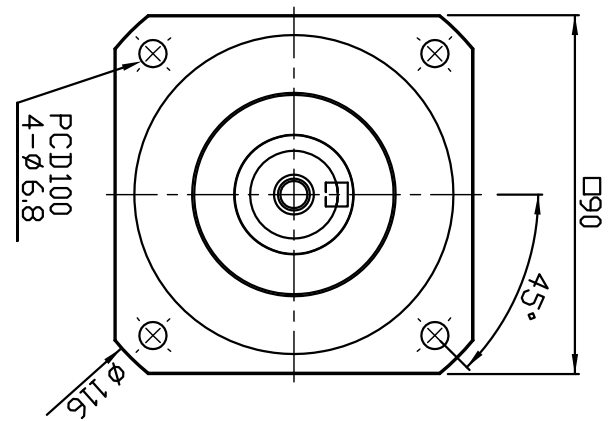

版本:A

- NOTES
1. Flange:L7MP90A-80-A2
 2. Output shaft have keyway, without keyway is optional.
 3. Bushing is supplide to input bore $\phi 19$ 、 $\phi 22$ 、 $\phi 24$

核准		日期		一般公差	尺寸範圍	密精度	備料	機種	FAB90
審核		日期			0.5-6	± 0.1	數量	圖名	成品圖
製圖	詹清堯	日期	2023.04.29		6-30	± 0.2	單位	料號	FAB90-1-80M5
					30-120	± 0.3	比例	版次	01
					120-315	± 0.5		路徑	
					315-1000	± 0.8		圖檔	FAB90-1-80M5
					1000-2000	± 1.2			

